

DESCRIPTION	DIMENSION A	DIMENSION B	LENS WIDTH	LENS RING
Standard Lens A06(TR:1.22~1.52)	113.57	590	Ø89	YES
Optional Lens A15(TR:0.75~0.95)	95.92	572	Ø104	YES
Optional Lens A16(TR:0.36)	348.47	825	250	NA
Optional Lens A01(TR:0.95~1.22)	94.56	571	Ø86	YES
Optional Lens A03(TR:1.52~2.92)	114.36	591	Ø86	YES
Optional Lens A13(TR:2.9~5.5)	142.07	619	Ø86	YES

外形寸法(WxDxH)	529x484x205mm (突起部含まず) 590x484x825mm (突起部含む)
質量	21.4kg (本体 17.4Kg+レンズ 4.0Kg)
明るさ	7500ルーメン
投写距離 (A16)	0.96m ~ 3.01m (120~400型)
防塵性能	IP5X

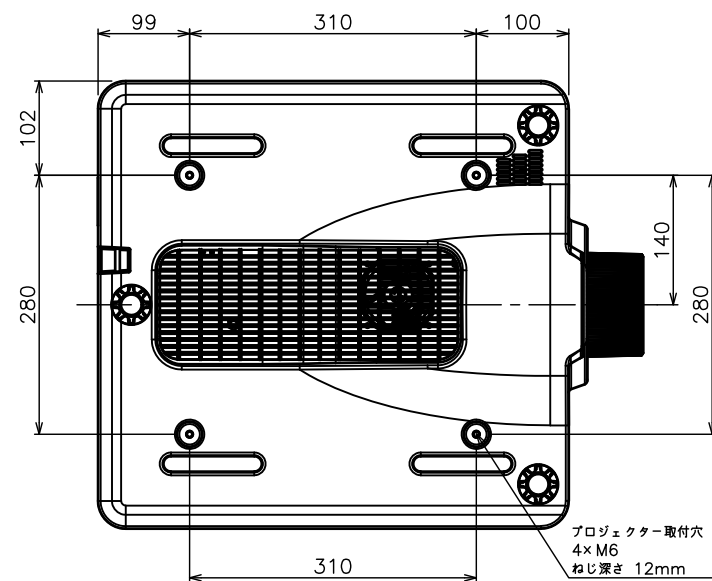
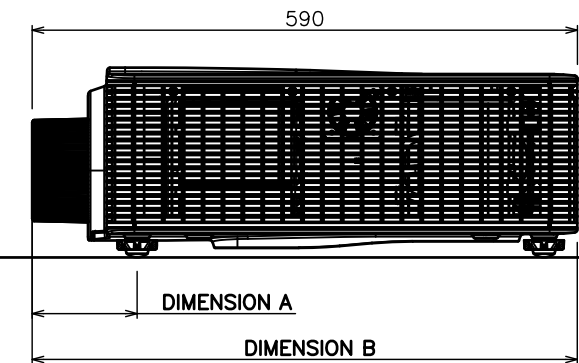
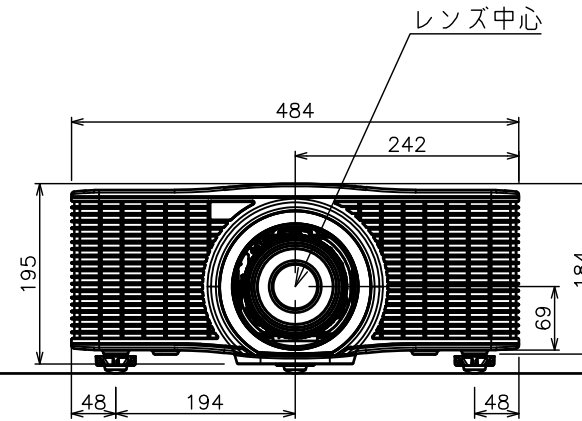
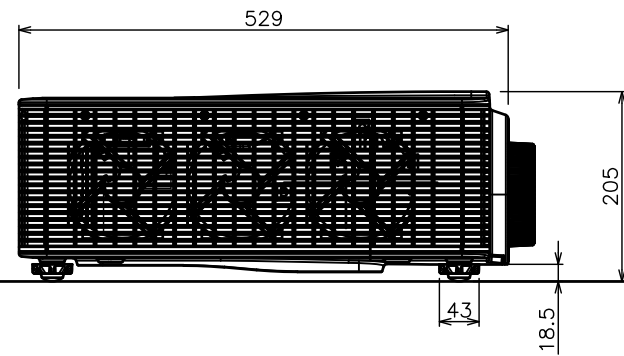
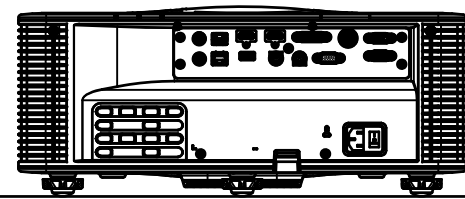
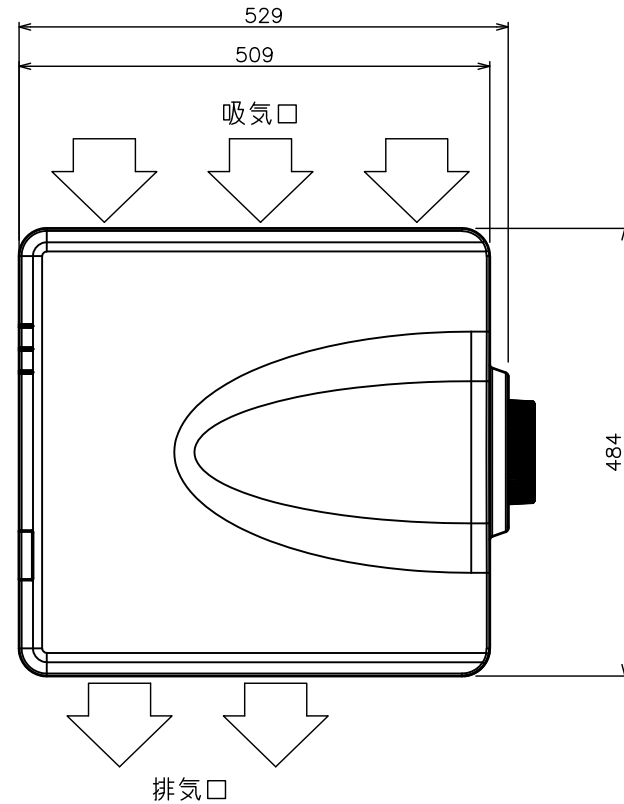
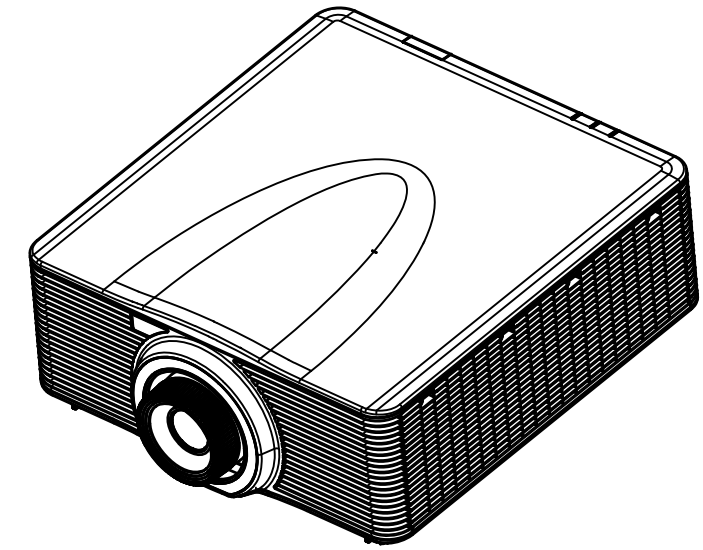

DESCRIPTION	DIMENSION A	DIMENSION B	LENS WIDTH	LENS RING
Standard Lens A06(TR:1.22~1.52)	113.57	590	Ø89	YES
Optional Lens A15(TR:0.75~0.95)	95.92	572	Ø104	YES
Optional Lens A16(TR:0.36)	348.47	825	250	NA
Optional Lens A01(TR:0.95~1.22)	94.56	571	Ø86	YES
Optional Lens A03(TR:1.52~2.92)	114.36	591	Ø86	YES
Optional Lens A13(TR:2.9~5.5)	142.07	619	Ø86	YES

外形寸法(WxDxH)	529x484x205mm (突起部含まず) 590x484x205mm (突起部含む)
質量	18.3kg (本体 17.4Kg+レンズ0.9Kg)
明るさ	7500ルーメン
投写距離 (A06)	1.29m ~ 16.58m (50~500型)
防塵性能	IP5X